

4

256 3225 000
THRU
256 3242 000

A				B				
CPLG SIZE	HUB DESIGN	MAX. BORE	DH	L	E	L1	T	SETSCREWS
42	1	2.125	3.74	4.96	1.02	1.97	.59	M8

NOTE: MAXIMUM SPEED FOR SIZE 42 COUPLING IS 3600 RPM.

"UL" MARKING TO APPEAR ON THIS SURFACE OF COUPLING HUB.

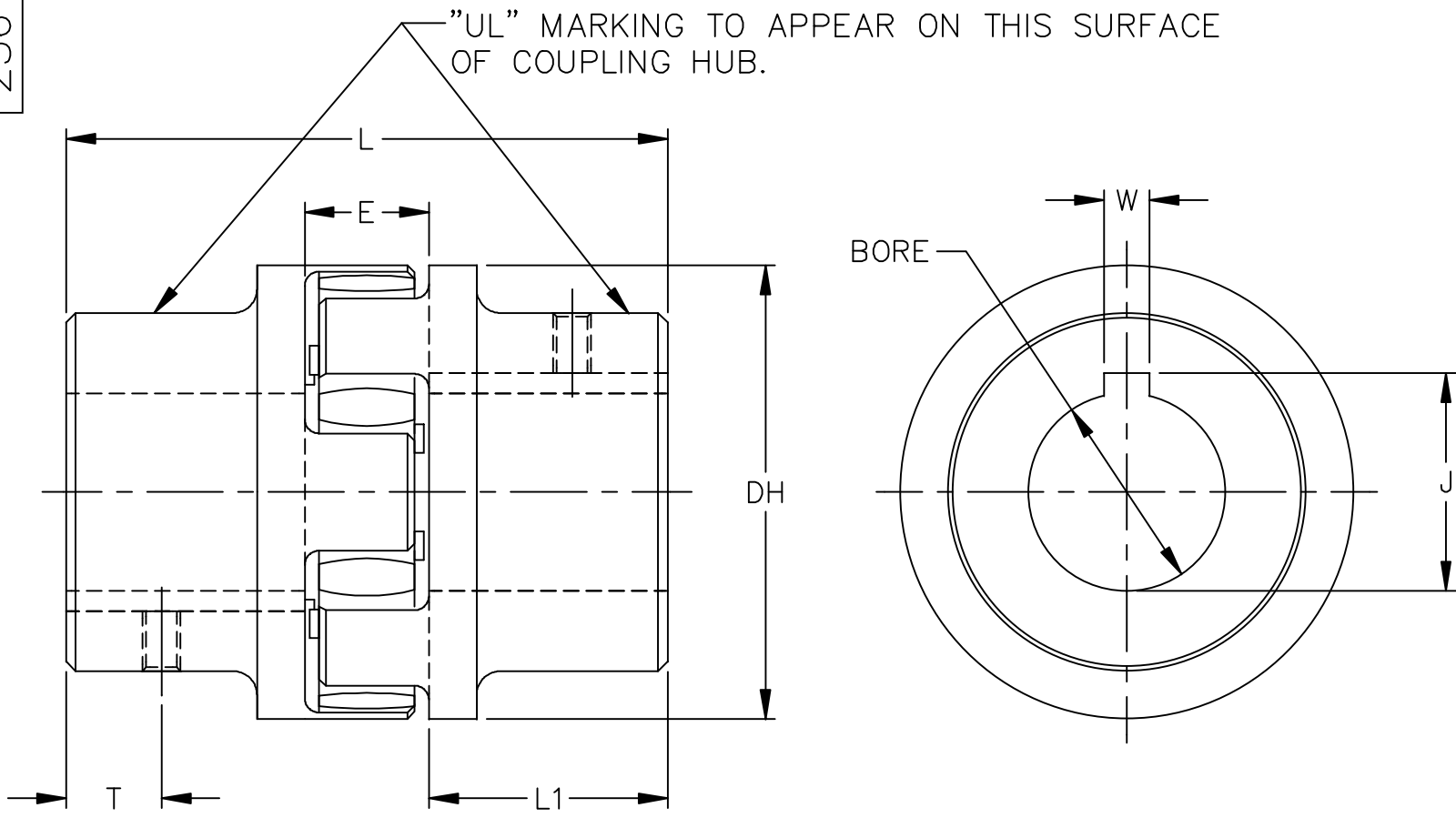

CPLG SIZE	BORE	KEYSEAT		J +.005 -.005	W +.002 -.000	PART NO.	
		STANDARD	SPECIAL				
42	.625	3/16x3/32	-	.714	.188	3225	
	.750	3/16x3/32	-	.842	.188	3226	
	.875	3/16x3/32	-	.969	.188	3227	
	1.000	1/4x1/8	-	1.119	.250	3228	
	1.063	1/4x1/8	-	1.183	.250	3229	
	1.125	1/4x1/8	-	1.246	.250	3230	
						3231	
	1.250	1/4x1/8	-	1.372	.250	3232	
						3233	
	1.375	5/16x5/32	-	1.523	.313	3234	
	1.375	-	3/8x3/16	-	1.546	.375	3235
	1.500	3/8x3/16	-	1.674	.375	3236	
	1.625	3/8x3/16	-	1.801	.375	3237	
	1.688	3/8x3/16	-	1.864	.375	3238	
	1.750	3/8x3/16	-	1.927	.375	3239	
1.875	1/2x1/4	-	2.101	.500	3240		
2.000	1/2x1/4	-	2.228	.500	3241		
2.125	1/2x1/4	-	2.355	.500	3242		

4

3

2

- NOTES:
1. THESE PART NUMBERS ARE FOR COUPLING HUB HALF ONLY. HUBS ARE SUPPLIED STANDARD WITH TWO SET SCREWS. INSERT SPIDERS REFERENCE PART NO. 448 1062 000. FOR COMPLETE COUPLING, TWO COUPLING HUBS ARE NEEDED WITH ONE INSERT SPIDER.
 2. KTR CORP. ROTEX 42 CURVE JAW COUPLINGS.
 3. FOR INCH SIZES, BORES TO BE CLEARANCE-FIT. INCH TOLERANCE PER AGMA 9002-A86 CLASS 1 FIT; KEYWAY TOLERANCES PER ANSI B17.1
 4. FOR METRIC SIZES, BORES TO BE CLEARANCE-FIT. METRIC TOLERANCE PER ISO H7 FIT; KEYWAY TOLERANCES PER DIN 6885, Js9
 5. KTR PART DESCRIPTION: ROTEX 42 STEEL COUPLING HUB.
 6. THESE COUPLING HUBS ARE COMPONENTS OF UL LISTED COUPLING.

THESE BORES PROVIDE A SLIP FIT.

BORE (IN.)	TOLERANCE
UP TO 2.000	+.001 TO -.000
OVER 2.000	+.0015 TO -.000

				DO NOT SCALE DRAWING PLOT SCALE .75 = 1		Pentair Water Pump Division North Aurora Operations				
A	5/26/11	INITIAL RELEASE TO SMARTTEAM	JD	JD	COMPANY CONFIDENTIAL: Information contained herein is confidential, it is the property of Pentair Water. It is to be used solely for the purpose provided, and it is not to be disclosed to others without the prior written consent of Pentair Water.					
REV	DATE	REVISION	BY	CK'D						
NOTES: 1. FINISH = 125 RMS. 2. 2 PLACE DECIMALS ± .06. 3. 3 PLACE DECIMALS ± .010. 4. ANGULAR DIMENSIONS ± 1/2°. 5. CHAMF. ALL MACH'D. SURFACE .005-.010x45° AND REMOVE ALL BURRS. 6. ALL PARTS MUST BE FREE FROM SCALE. 7. NO TOLERANCE NEEDED ON REFERENCE DIMENSIONS. 8. ALL BOLT CIRCLE TOLERANCE PER ANSI B16.5. 9. CONCENTRICITY TO CENTERLINE .005.					STANDARD TOLERANCES UNLESS OTHERWISE SPECIFIED.		DRAWN BY JPD DATE 05/26/11 CHECKED BY JLF APPROVED BY JLF		CURVE JAW TYPE COUPLINGS ROTEX 42 ELASTOMER-IN-COMPRESSION UL REV A 256 3225 000 SIZE THRU B 256 3242 000	

1

A					B				
CPLG SIZE	HUB DESIGN	MAX. BORE	DH	L	E	L1	T	SETSCREWS	
55	1	2.813	4.72	6.30	1.18	2.56	.79	M10	

NOTE: MAXIMUM SPEED FOR SIZE 55 COUPLING IS 3600 RPM.

"UL" MARKING TO APPEAR ON THIS SURFACE OF COUPLING HUB.

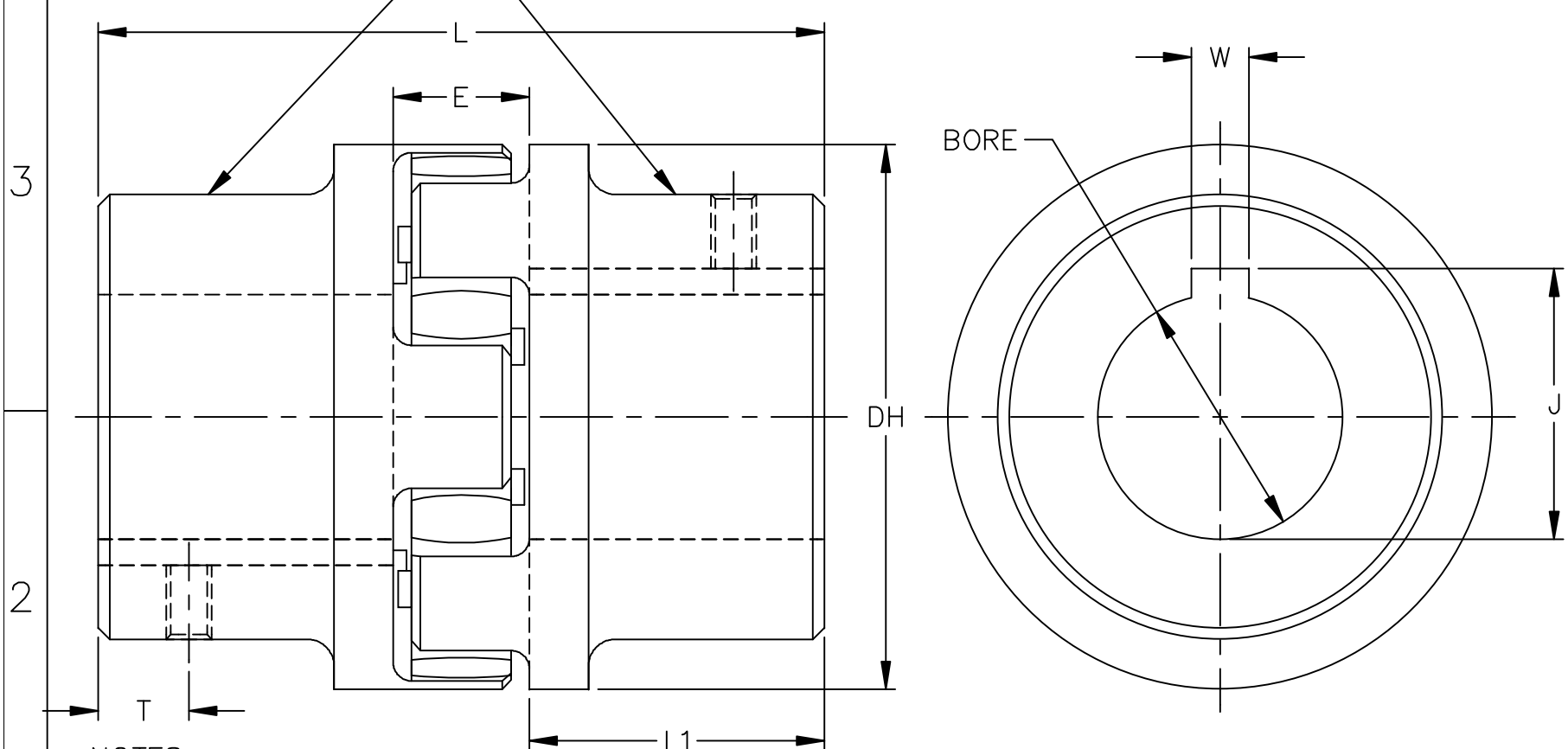

CPLG SIZE	BORE	KEYSEAT		J +.005 -.005	W +.002 -.000	PART NO.
		STANDARD	SPECIAL			
55						3243
	1.063	1/4x1/8	-	1.183	.250	3244
	1.125	1/4x1/8	-	1.246	.250	3245
	1.250	1/4x1/8	-	1.372	.250	3246
	1.375	5/16x5/32	-	1.523	.313	3247
	1.375	-	3/8x3/16	1.546	.375	3248
	1.500	3/8x3/16	-	1.674	.375	3249
	1.625	3/8x3/16	-	1.801	.375	3250
	1.688	3/8x3/16	-	1.864	.375	3251
	1.750	3/8x3/16	-	1.927	.375	3252
	1.875	1/2x1/4	-	2.101	.500	3253
	2.000	1/2x1/4	-	2.228	.500	3254
	2.125	1/2x1/4	-	2.355	.500	3255
	2.250	1/2x1/4	-	2.355	.500	3256
	2.375	5/8x5/16	-	2.656	.625	3257
	2.500	5/8x5/16	-	2.783	.625	3258
2.625	5/8x5/16	-	2.910	.625	3259	
2.750	5/8x5/16	-	3.037	.625	3260	

- NOTES:
1. THESE PART NUMBERS ARE FOR COUPLING HUB HALF ONLY. HUBS ARE SUPPLIED STANDARD WITH TWO SET SCREWS. INSERT SPIDERS REFERENCE PART NO. 448 1063 000. FOR COMPLETE COUPLING, TWO COUPLING HUBS ARE NEEDED WITH ONE INSERT SPIDER.
 2. KTR CORP. ROTEX 55 CURVE JAW COUPLINGS.
 3. FOR INCH SIZES, BORES TO BE CLEARANCE-FIT. INCH TOLERANCE PER AGMA 9002-A86 CLASS 1 FIT; KEYWAY TOLERANCES PER ANSI B17.1
 4. FOR METRIC SIZES, BORES TO BE CLEARANCE-FIT. METRIC TOLERANCE PER ISO H7 FIT; KEYWAY TOLERANCES PER DIN 6885, Js9
 5. KTR PART DESCRIPTION: ROTEX 55 STEEL COUPLING HUB.
 6. THESE COUPLING HUBS ARE COMPONENTS OF UL LISTED COUPLING.

THESE BORES PROVIDE A SLIP FIT.

BORE (IN.)	TOLERANCE
UP TO 2.000	+.001 TO -.000
OVER 2.000	+.0015 TO -.000

				DO NOT SCALE DRAWING PLOT SCALE .75 = 1		Pentair Water Pump Division North Aurora Operations		
A	5/26/11	INITIAL RELEASE TO SMARTTEAM	JD	JD	COMPANY CONFIDENTIAL: Information contained herein is confidential, it is the property of Pentair Water. It is to be used solely for the purpose provided, and it is not to be disclosed to others without the prior written consent of Pentair Water.			
REV	DATE	REVISION	BY	CK'D				
NOTES:					STANDARD TOLERANCES UNLESS OTHERWISE SPECIFIED.		DRAWN BY JPD	
1. FINISH = 125 RMS.							CURVE JAW TYPE COUPLINGS ROTEX	
2. 2 PLACE DECIMALS ± .06.							55 ELASTOMER-IN-COMPRESSION UL	
3. 3 PLACE DECIMALS ± .010.							REV A	
4. ANGULAR DIMENSIONS ± 1/2°.							256 3243 000	
5. CHAMF. ALL MACH'D. SURFACE .005-.010x45° AND REMOVE ALL BURRS.							THRU	
6. ALL PARTS MUST BE FREE FROM SCALE.							SIZE B	
7. NO TOLERANCE NEEDED ON REFERENCE DIMENSIONS.							256 3260 000	
8. ALL BOLT CIRCLE TOLERANCE PER ANSI B16.5.								
9. CONCENTRICITY TO CENTERLINE .005.								

256 3261 000
THRU
256 3278 000

A				B				
CPLG SIZE	HUB DESIGN	MAX. BORE	DH	L	E	L1	T	SETSCREWS
65	1	3.000	5.31	7.28	1.38	2.95	.79	M10

NOTE: MAXIMUM SPEED FOR SIZE 65 COUPLING IS 3600 RPM.

"UL" MARKING TO APPEAR ON THIS SURFACE OF COUPLING HUB.

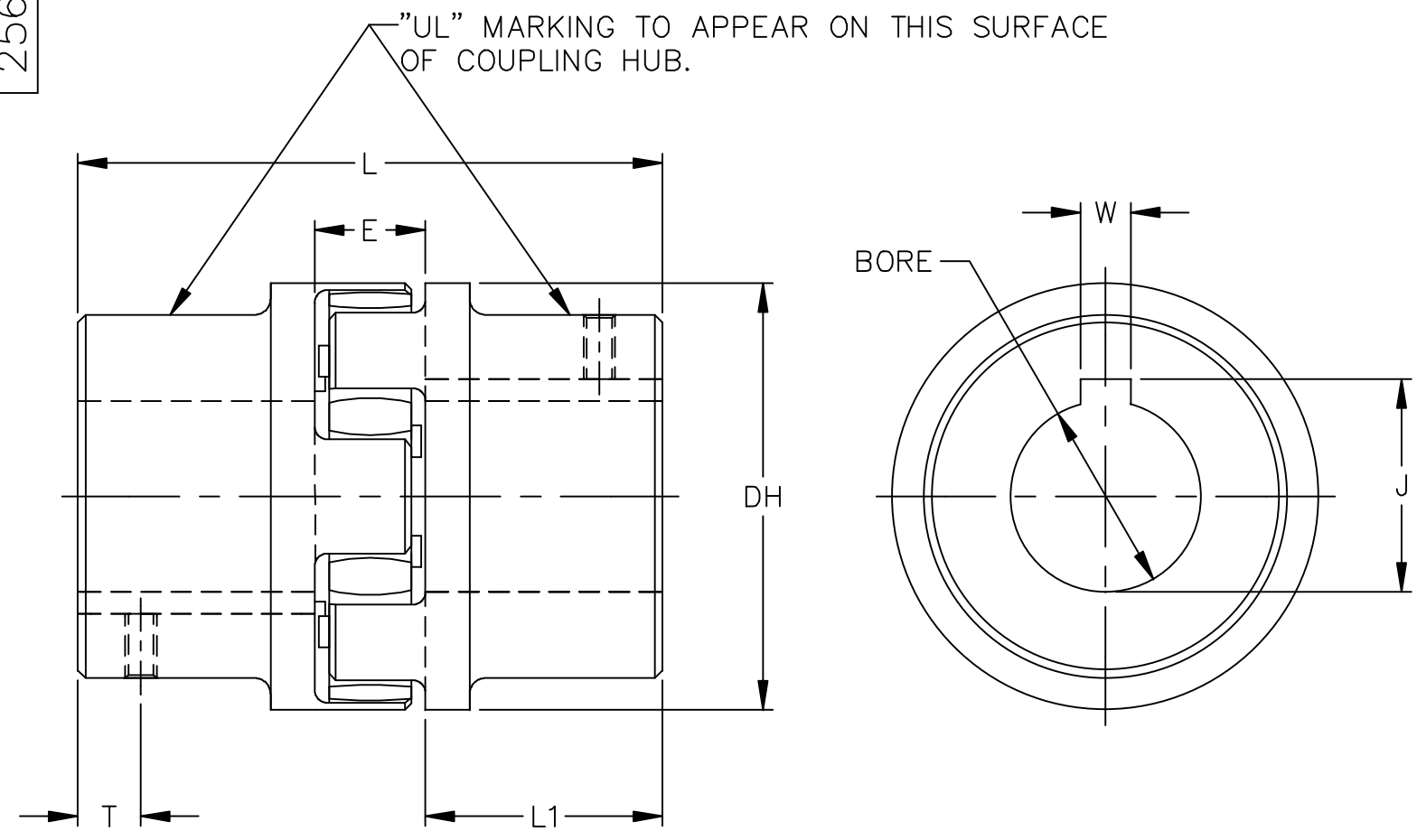

CPLG SIZE	BORE	KEYSEAT		J +.005 -.005	W +.002 -.000	PART NO.
		STANDARD	SPECIAL			
65	1.125	1/4x1/8	-	1.246	.250	3261
	1.250	1/4x1/8	-	1.372	.250	3262
	1.375	5/16x5/32	-	1.523	.313	3263
	1.375	-	3/8x3/16	1.546	.375	3264
	1.500	3/8x3/16	-	1.674	.375	3265
	1.625	3/8x3/16	-	1.801	.375	3266
	1.688	3/8x3/16	-	1.864	.375	3267
	1.750	3/8x3/16	-	1.927	.375	3268
	1.875	1/2x1/4	-	2.101	.500	3269
	2.000	1/2x1/4	-	2.228	.500	3270
	2.125	1/2x1/4	-	2.355	.500	3271
	2.250	1/2x1/4	-	2.355	.500	3272
	2.375	5/8x5/16	-	2.656	.625	3273
	2.500	5/8x5/16	-	2.783	.625	3274
	2.625	5/8x5/16	-	2.910	.625	3275
	2.750	5/8x5/16	-	3.037	.625	3276
	2.875	3/4x3/8	-	3.210	.750	3277
3.000	3/4x3/8	-	3.337	.750	3278	

- NOTES:
1. THESE PART NUMBERS ARE FOR COUPLING HUB HALF ONLY. HUBS ARE SUPPLIED STANDARD WITH TWO SET SCREWS. INSERT SPIDERS REFERENCE PART NO. 448 1064 000. FOR COMPLETE COUPLING, TWO COUPLING HUBS ARE NEEDED WITH ONE INSERT SPIDER.
 2. KTR CORP. ROTEX 65 CURVE JAW COUPLINGS.
 3. FOR INCH SIZES, BORES TO BE CLEARANCE-FIT. INCH TOLERANCE PER AGMA 9002-A86 CLASS 1 FIT; KEYWAY TOLERANCES PER ANSI B17.1
 4. FOR METRIC SIZES, BORES TO BE CLEARANCE-FIT. METRIC TOLERANCE PER ISO H7 FIT; KEYWAY TOLERANCES PER DIN 6885, Js9
 5. KTR PART DESCRIPTION: ROTEX 65 STEEL COUPLING HUB.
 6. THESE COUPLING HUBS ARE COMPONENTS OF UL LISTED COUPLING.

THESE BORES PROVIDE A SLIP FIT.

BORE (IN.)	TOLERANCE
UP TO 2.000	+.001 TO -.000
OVER 2.000	+.0015 TO -.000

				DO NOT SCALE DRAWING PLOT SCALE .50 = 1		Pentair Water Pump Division North Aurora Operations		
A	5/26/11	INITIAL RELEASE TO SMARTTEAM	JD	JD	COMPANY CONFIDENTIAL: Information contained herein is confidential, it is the property of Pentair Water. It is to be used solely for the purpose provided, and it is not to be disclosed to others without the prior written consent of Pentair Water.			
REV	DATE	REVISION	BY	CK'D				
NOTES:					STANDARD TOLERANCES UNLESS OTHERWISE SPECIFIED.		DRAWN BY JPD	
1. FINISH = 125 RMS.					DATE 05/26/11		CURVE JAW TYPE COUPLINGS ROTEX 65 ELASTOMER-IN-COMPRESSION UL	
2. 2 PLACE DECIMALS ± .06.					CHECKED BY JLF		REV A 256 3261 000	
3. 3 PLACE DECIMALS ± .010.					APPROVED BY JLF		SIZE B 256 3278 000	
4. ANGULAR DIMENSIONS ± 1/2°.								
5. CHAMF. ALL MACH'D. SURFACE .005-.010x45° AND REMOVE ALL BURRS.								
6. ALL PARTS MUST BE FREE FROM SCALE.								
7. NO TOLERANCE NEEDED ON REFERENCE DIMENSIONS.								
8. ALL BOLT CIRCLE TOLERANCE PER ANSI B16.5.								
9. CONCENTRICITY TO CENTERLINE .005.								

A					B				
CPLG SIZE	HUB DESIGN	MAX. BORE	DH	L	E	L1	T	SETSCREWS	
75	1	3.625	6.30	8.27	1.57	3.35	.79	M10	

NOTE: MAXIMUM SPEED FOR SIZE 75 COUPLING IS 1800 RPM.

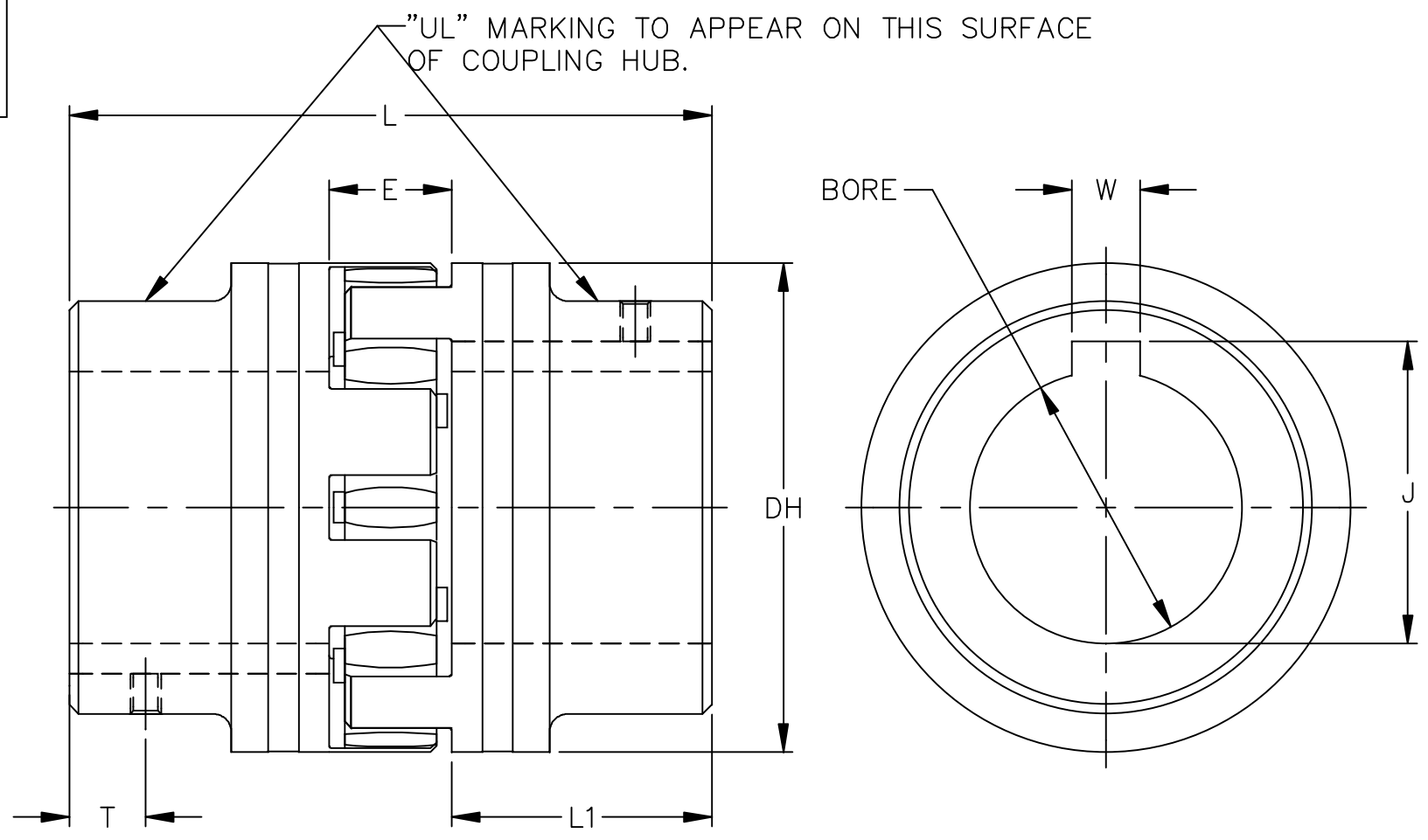

CPLG SIZE	BORE	KEYSEAT		J +.005 -.005	W +.002 -.000	PART NO.
		STANDARD	SPECIAL			
75	1.125	1/4x1/8	-	1.246	.250	3279
	1.250	1/4x1/8	-	1.372	.250	3280
	1.375	5/16x5/32	-	1.523	.313	3281
	1.375	-	3/8x3/16	1.546	.375	3282
	1.500	3/8x3/16	-	1.674	.375	3283
	1.625	3/8x3/16	-	1.801	.375	3284
	1.688	3/8x3/16	-	1.864	.375	3285
	1.750	3/8x3/16	-	1.927	.375	3286
	1.875	1/2x1/4	-	2.101	.500	3287
	2.000	1/2x1/4	-	2.228	.500	3288
	2.125	1/2x1/4	-	2.355	.500	3289
	2.250	1/2x1/4	-	2.355	.500	3290
	2.375	5/8x5/16	-	2.656	.625	3291
	2.500	5/8x5/16	-	2.783	.625	3292
	2.625	5/8x5/16	-	2.910	.625	3293
	2.750	5/8x5/16	-	3.037	.625	3294
	2.875	3/4x3/8	-	3.210	.750	3295
	3.375	7/8x7/16	-	3.765	.875	3296
3.500	7/8x7/16	-	3.892	.875	3297	
3.625	7/8x7/16	-	4.019	.875	3298	

- NOTES:
1. THESE PART NUMBERS ARE FOR COUPLING HUB HALF ONLY. HUBS ARE SUPPLIED STANDARD WITH TWO SET SCREWS. INSERT SPIDERS REFERENCE PART NO. 448 1065 000. FOR COMPLETE COUPLING, TWO COUPLING HUBS ARE NEEDED WITH ONE INSERT SPIDER.
 2. KTR CORP. ROTEX 75 CURVE JAW COUPLINGS.
 3. FOR INCH SIZES, BORES TO BE CLEARANCE-FIT. INCH TOLERANCE PER AGMA 9002-A86 CLASS 1 FIT; KEYWAY TOLERANCES PER ANSI B17.1
 4. FOR METRIC SIZES, BORES TO BE CLEARANCE-FIT. METRIC TOLERANCE PER ISO H7 FIT; KEYWAY TOLERANCES PER DIN 6885, Js9
 5. KTR PART DESCRIPTION: ROTEX 75 STEEL COUPLING HUB.
 6. THESE COUPLING HUBS ARE COMPONENTS OF UL LISTED COUPLING.

THESE BORES PROVIDE A SLIP FIT.

BORE (IN.)	TOLERANCE
UP TO 2.000	+.001 TO -.000
OVER 2.000	+.0015 TO -.000

				DO NOT SCALE DRAWING PLOT SCALE .50 = 1		Pentair Water Pump Division North Aurora Operations		
A	5/26/11	INITIAL RELEASE TO SMARTTEAM	JD	JD	COMPANY CONFIDENTIAL: Information contained herein is confidential, it is the property of Pentair Water. It is to be used solely for the purpose provided, and it is not to be disclosed to others without the prior written consent of Pentair Water.			
REV	DATE	REVISION	BY	CK'D				
NOTES:					STANDARD TOLERANCES UNLESS OTHERWISE SPECIFIED.		DRAWN BY JPD	
1. FINISH = 125 RMS.							CURVE JAW TYPE COUPLINGS ROTEX 75 ELASTOMER-IN-COMPRESSION UL	
2. 2 PLACE DECIMALS ± .06.							REV A	
3. 3 PLACE DECIMALS ± .010.							256 3279 000	
4. ANGULAR DIMENSIONS ± 1/2°.							THRU	
5. CHAMF. ALL MACH'D. SURFACE .005-.010x45° AND REMOVE ALL BURRS.							B	
6. ALL PARTS MUST BE FREE FROM SCALE.							256 3298 000	
7. NO TOLERANCE NEEDED ON REFERENCE DIMENSIONS.								
8. ALL BOLT CIRCLE TOLERANCE PER ANSI B16.5.								
9. CONCENTRICITY TO CENTERLINE .005.								
				CHECKED BY JLF				
				APPROVED BY JLF				

A				B				C		D				
CPLG SIZE	HUB DESIGN	MAX. BORE	DH	L	E	L1	T	SETSCREWS	CPLG SIZE	BORE	KEYSEAT	J +.005 -.005	W +.002 -.000	PART NO.
90	1	4.250	7.87	9.65	1.77	3.94	1.18	M16						

NOTE: MAXIMUM SPEED FOR SIZE 90 COUPLING IS 1800 RPM.

256 3299 000
THRU
256 3320 000

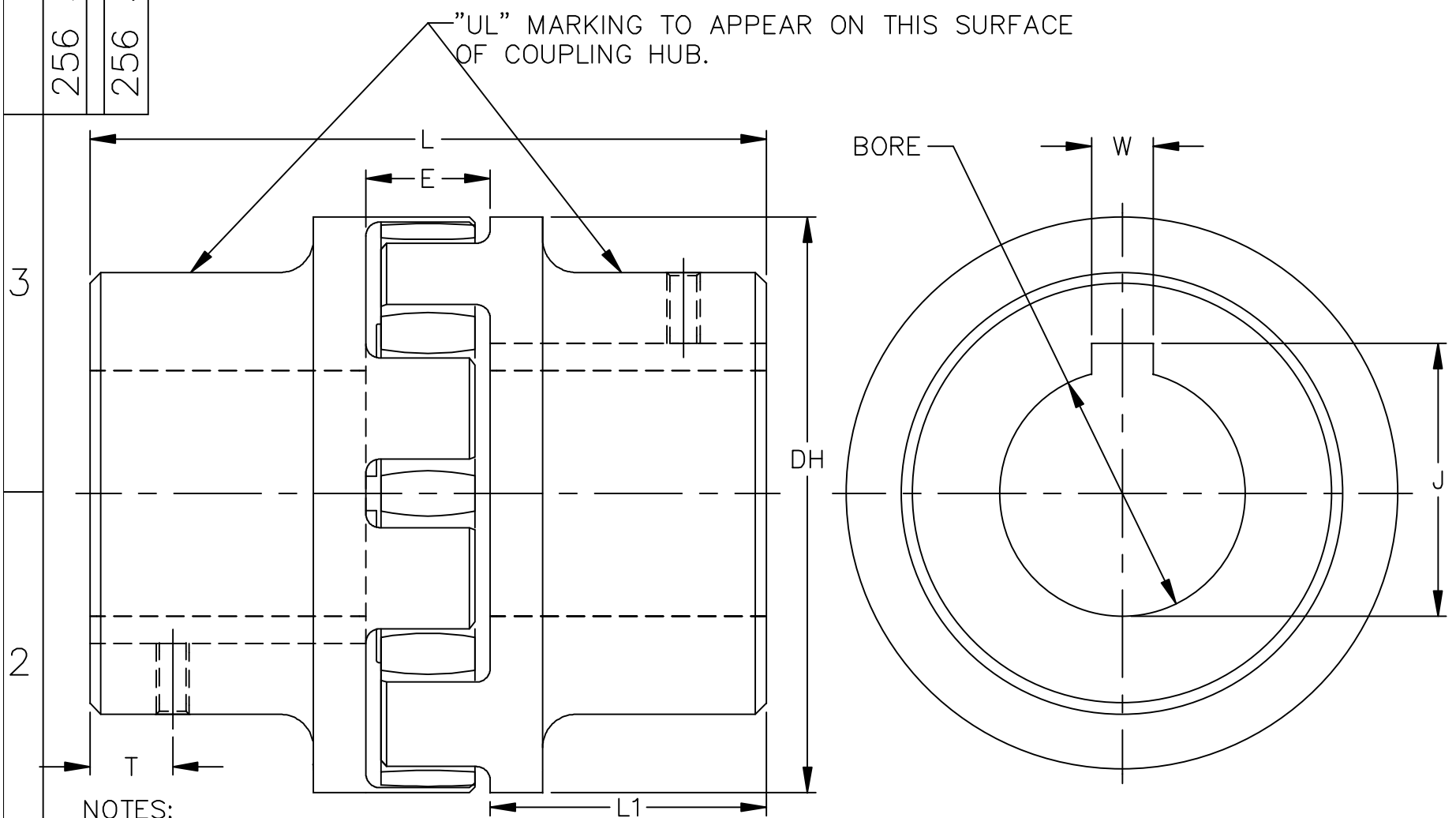

CPLG SIZE	BORE	KEYSEAT		J +.005 -.005	W +.002 -.000	PART NO.
		STANDARD	SPECIAL			
90	1.625	3/8x3/16	-	1.801	.375	3299
	1.750	3/8x3/16	-	1.927	.375	3300
	1.875	1/2x1/4	-	2.101	.500	3301
	2.000	1/2x1/4	-	2.228	.500	3302
	2.125	1/2x1/4	-	2.355	.500	3303
	2.250	1/2x1/4	-	2.355	.500	3304
	2.375	5/8x5/16	-	2.656	.625	3305
	2.500	5/8x5/16	-	2.783	.625	3306
	2.625	5/8x5/16	-	2.910	.625	3307
	2.750	5/8x5/16	-	3.037	.625	3308
	2.875	3/4x3/8	-	3.210	.750	3309
	3.000	3/4x3/8	-	3.337	.750	3310
	3.125	3/4x3/8	-	3.454	.750	3311
	1.500	3/8x3/16	-	1.674	.375	3312
	3.375	7/8x7/16	-	3.765	.875	3313
	3.500	7/8x7/16	-	3.892	.875	3314
	3.625	7/8x7/16	-	4.019	.875	3315
	3.750	7/8x7/16	-	4.146	.875	3316
	3.875	1x1/2	-	4.319	1.000	3317
	4.125	1x1/2	-	4.573	1.000	3318
	4.250	1x1/2	-	4.700	1.000	3319
	1.688	3/8x3/16	-	1.864	.375	3320

- NOTES:
1. THESE PART NUMBERS ARE FOR COUPLING HUB HALF ONLY. HUBS ARE SUPPLIED STANDARD WITH TWO SET SCREWS. INSERT SPIDERS REFERENCE PART NO. 448 1066 000. FOR COMPLETE COUPLING, TWO COUPLING HUBS ARE NEEDED WITH ONE INSERT SPIDER.
 2. KTR CORP. ROTEX 90 CURVE JAW COUPLINGS.
 3. FOR INCH SIZES, BORES TO BE CLEARANCE-FIT. INCH TOLERANCE PER AGMA 9002-A86 CLASS 1 FIT; KEYWAY TOLERANCES PER ANSI B17.1
 4. FOR METRIC SIZES, BORES TO BE CLEARANCE-FIT. METRIC TOLERANCE PER ISO H7 FIT; KEYWAY TOLERANCES PER DIN 6885, Js9
 5. KTR PART DESCRIPTION: ROTEX 90 STEEL COUPLING HUB.
 6. THESE COUPLING HUBS ARE COMPONENTS OF UL LISTED COUPLING.

THESE BORES PROVIDE A SLIP FIT.

BORE (IN.)	TOLERANCE
UP TO 2.000	+.001 TO -.000
OVER 2.000	+.0015 TO -.000

DO NOT SCALE DRAWING PLOT SCALE .50 = 1				Pentair Water Pump Division North Aurora Operations	
B	6/13/11	ADD P/N 3320	JD	JD	COMPANY CONFIDENTIAL: Information contained herein is confidential, it is the property of Pentair Water. It is to be used solely for the purpose provided, and it is not to be disclosed to others without the prior written consent of Pentair Water.
A	5/26/11	INITIAL RELEASE TO SMARTTEAM	JD	JD	
REV	DATE	REVISION	BY	CK'D	
NOTES:				STANDARD TOLERANCES UNLESS OTHERWISE SPECIFIED.	
1. FINISH = 125 RMS.				DRAWN BY JPD	
2. 2 PLACE DECIMALS ± .06.				DATE 05/26/11	
3. 3 PLACE DECIMALS ± .010.				CHECKED BY JLF	
4. ANGULAR DIMENSIONS ± 1/2°.				APPROVED BY JLF	
5. CHAMF. ALL MACH'D. SURFACE .005-.010x45° AND REMOVE ALL BURRS.				CURVE JAW TYPE COUPLINGS ROTEX 90 ELASTOMER-IN-COMPRESSION UL	
6. ALL PARTS MUST BE FREE FROM SCALE.				REV B	
7. NO TOLERANCE NEEDED ON REFERENCE DIMENSIONS.				SIZE	
8. ALL BOLT CIRCLE TOLERANCE PER ANSI B16.5.				B 256 3299 000	
9. CONCENTRICITY TO CENTERLINE .005.				THRU B 256 3320 000	

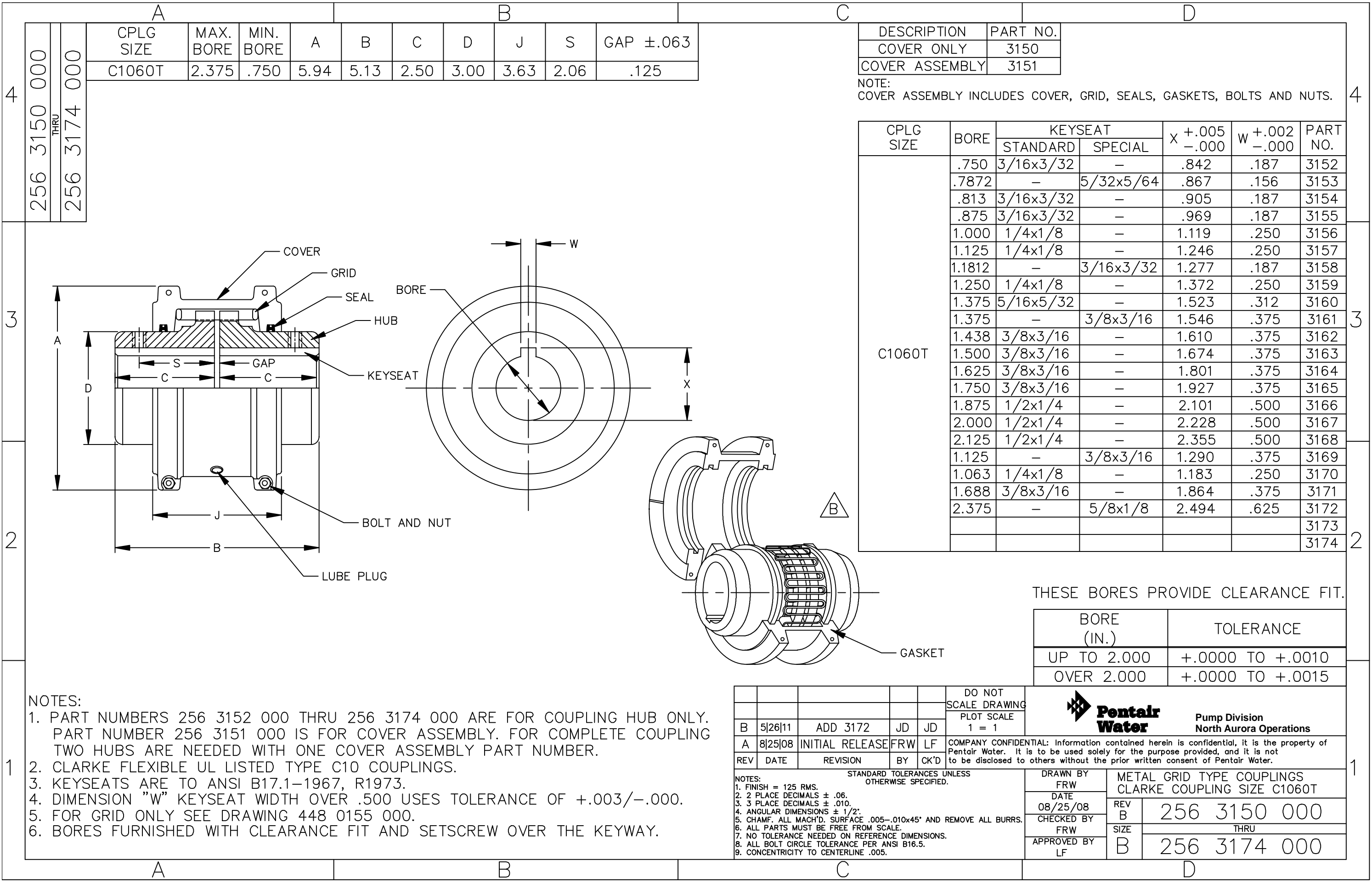

4
256 3150 000
THRU
256 3174 000

CPLG SIZE	MAX. BORE	MIN. BORE	A	B	C	D	J	S	GAP ±.063
C1060T	2.375	.750	5.94	5.13	2.50	3.00	3.63	2.06	.125

DESCRIPTION	PART NO.
COVER ONLY	3150
COVER ASSEMBLY	3151

NOTE:
COVER ASSEMBLY INCLUDES COVER, GRID, SEALS, GASKETS, BOLTS AND NUTS.

CPLG SIZE	BORE	KEYSEAT		X +.005 -.000	W +.002 -.000	PART NO.
		STANDARD	SPECIAL			
C1060T	.750	3/16x3/32	-	.842	.187	3152
	.7872	-	5/32x5/64	.867	.156	3153
	.813	3/16x3/32	-	.905	.187	3154
	.875	3/16x3/32	-	.969	.187	3155
	1.000	1/4x1/8	-	1.119	.250	3156
	1.125	1/4x1/8	-	1.246	.250	3157
	1.1812	-	3/16x3/32	1.277	.187	3158
	1.250	1/4x1/8	-	1.372	.250	3159
	1.375	5/16x5/32	-	1.523	.312	3160
	1.375	-	3/8x3/16	1.546	.375	3161
	1.438	3/8x3/16	-	1.610	.375	3162
	1.500	3/8x3/16	-	1.674	.375	3163
	1.625	3/8x3/16	-	1.801	.375	3164
	1.750	3/8x3/16	-	1.927	.375	3165
	1.875	1/2x1/4	-	2.101	.500	3166
	2.000	1/2x1/4	-	2.228	.500	3167
	2.125	1/2x1/4	-	2.355	.500	3168
	1.125	-	3/8x3/16	1.290	.375	3169
	1.063	1/4x1/8	-	1.183	.250	3170
	1.688	3/8x3/16	-	1.864	.375	3171
2.375	-	5/8x1/8	2.494	.625	3172	
					3173	
					3174	

THESE BORES PROVIDE CLEARANCE FIT.

BORE (IN.)	TOLERANCE
UP TO 2.000	+.0000 TO +.0010
OVER 2.000	+.0000 TO +.0015

- NOTES:
- PART NUMBERS 256 3152 000 THRU 256 3174 000 ARE FOR COUPLING HUB ONLY. PART NUMBER 256 3151 000 IS FOR COVER ASSEMBLY. FOR COMPLETE COUPLING TWO HUBS ARE NEEDED WITH ONE COVER ASSEMBLY PART NUMBER.
 - CLARKE FLEXIBLE UL LISTED TYPE C10 COUPLINGS.
 - KEYSEATS ARE TO ANSI B17.1-1967, R1973.
 - DIMENSION "W" KEYSEAT WIDTH OVER .500 USES TOLERANCE OF +.003/- .000.
 - FOR GRID ONLY SEE DRAWING 448 0155 000.
 - BORES FURNISHED WITH CLEARANCE FIT AND SETSCREW OVER THE KEYWAY.

				DO NOT SCALE DRAWING		Pentair Water Pump Division North Aurora Operations	
				PLOT SCALE 1 = 1			
B	5/26/11	ADD 3172	JD	JD	COMPANY CONFIDENTIAL: Information contained herein is confidential, it is the property of Pentair Water. It is to be used solely for the purpose provided, and it is not to be disclosed to others without the prior written consent of Pentair Water.		
A	8/25/08	INITIAL RELEASE	FRW	LF			
REV	DATE	REVISION	BY	CK'D			
NOTES:				STANDARD TOLERANCES UNLESS OTHERWISE SPECIFIED.		DRAWN BY FRW	
1. FINISH = 125 RMS.						METAL GRID TYPE COUPLINGS	
2. 2 PLACE DECIMALS ± .06.						CLARKE COUPLING SIZE C1060T	
3. 3 PLACE DECIMALS ± .010.						REV B	256 3150 000
4. ANGULAR DIMENSIONS ± 1/2°.						SIZE	THRU
5. CHAMF. ALL MACH'D. SURFACE .005--.010x45° AND REMOVE ALL BURRS.						B	256 3174 000
6. ALL PARTS MUST BE FREE FROM SCALE.							
7. NO TOLERANCE NEEDED ON REFERENCE DIMENSIONS.							
8. ALL BOLT CIRCLE TOLERANCE PER ANSI B16.5.							
9. CONCENTRICITY TO CENTERLINE .005.							

A				B				C				D			
CPLG SIZE	MAX. BORE	MIN. BORE	A	B	C	D	J	S	GAP	±.063					
C1080T	3.000	1.063	7.63	7.13	3.50	4.13	4.56	2.54	.125						

DESCRIPTION	PART NO.
COVER ONLY	3200
COVER ASSEMBLY	3201

NOTE:
COVER ASSEMBLY INCLUDES COVER, GRID, SEALS, GASKETS, BOLTS AND NUTS.

CPLG SIZE	BORE	KEYSEAT		X +.005 -.000	W +.002 -.000	PART NO.
		STANDARD	SPECIAL			
C1080T	1.125	1/4x1/8	-	1.246	.250	3202
	1.1812	-	3/16x3/32	1.277	.187	3203
	1.250	1/4x1/8	-	1.372	.250	3204
	1.375	5/16x5/32	-	1.523	.312	3205
	1.375	-	3/8x3/16	1.546	.375	3206
	1.438	3/8x3/16	-	1.610	.375	3207
	1.500	3/8x3/16	-	1.674	.375	3208
	1.625	3/8x3/16	-	1.801	.375	3209
	1.750	3/8x3/16	-	1.927	.375	3210
	1.875	1/2x1/4	-	2.101	.500	3211
	2.000	1/2x1/4	-	2.228	.500	3212
	2.125	1/2x1/4	-	2.355	.500	3213
	2.250	1/2x1/4	-	2.482	.500	3214
	2.375	5/8x5/16	-	2.656	.625	3215
	2.500	5/8x5/16	-	2.783	.625	3216
	2.625	5/8x5/16	-	2.910	.625	3217
	2.750	5/8x5/16	-	3.037	.625	3218
	2.875	3/4x3/8	-	3.210	.750	3219
	3.000	3/4x3/8	-	3.337	.750	3220
	2.750	-	3/4x3/8	3.083	.750	3221
2.250	-	5/8x5/16	2.528	.625	3222	
1.688	3/8x3/16	-	1.864	.375	3223	
					3224	

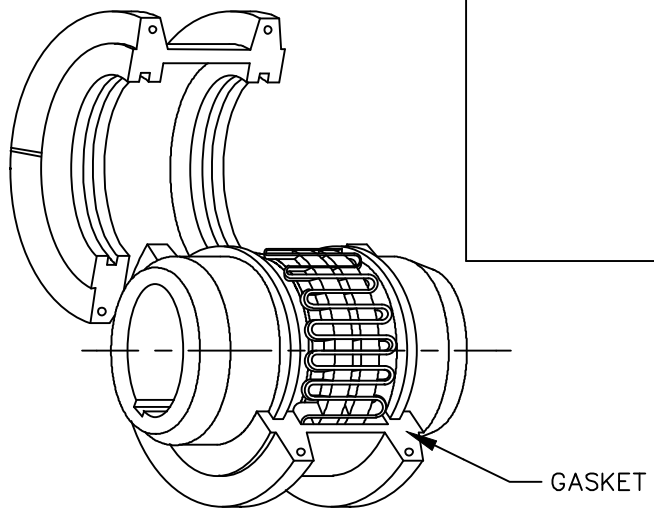
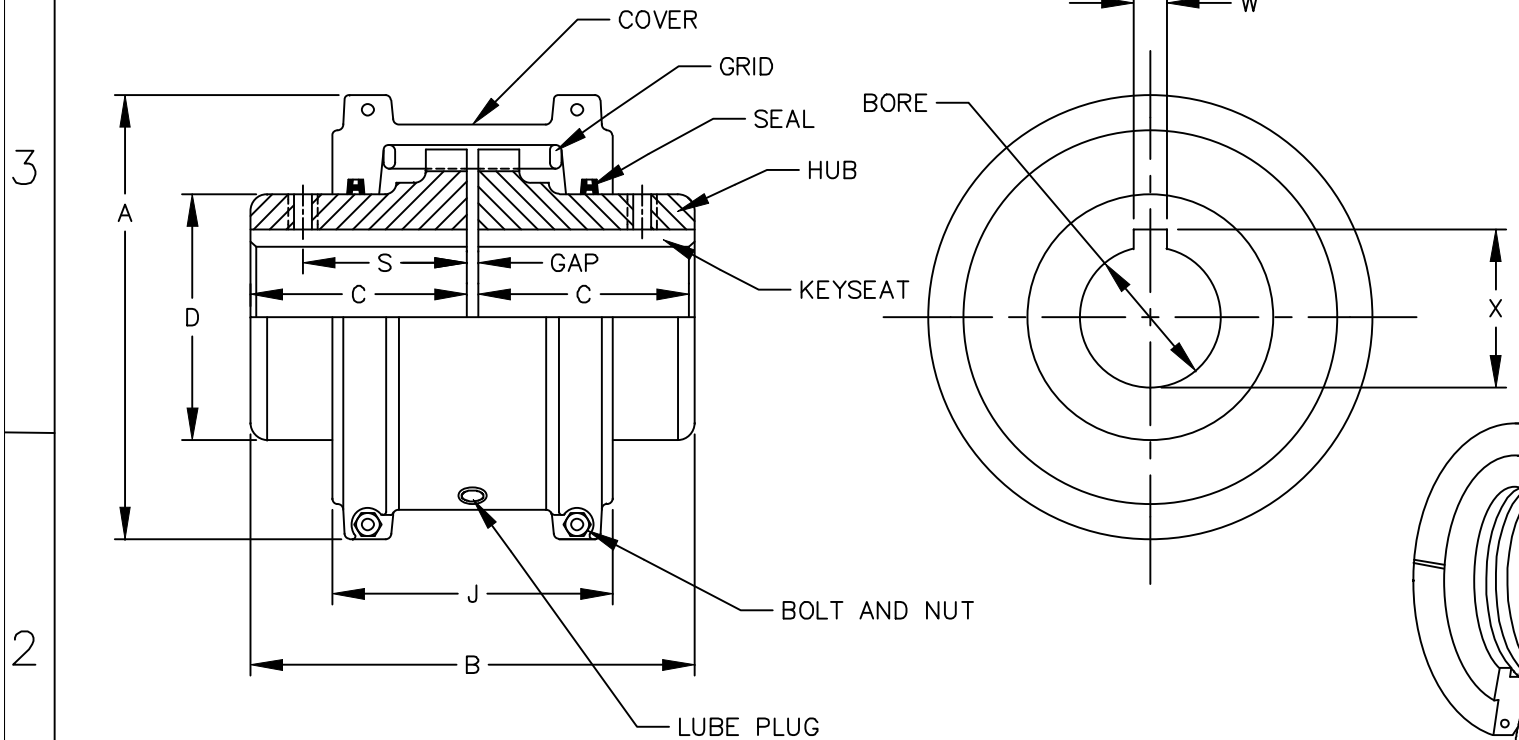

THESE BORES PROVIDE CLEARANCE FIT.

BORE (IN.)	TOLERANCE
UP TO 2.000	+.0000 TO +.0010
OVER 2.000	+.0000 TO +.0015

- NOTES:
- PART NUMBERS 256 3202 000 THRU 256 3223 000 ARE FOR COUPLING HUB ONLY. PART NUMBER 256 3201 000 IS FOR COVER ASSEMBLY. FOR COMPLETE COUPLING TWO HUBS ARE NEEDED WITH ONE COVER ASSEMBLY PART NUMBER.
 - CLARKE FLEXIBLE UL LISTED TYPE C10 COUPLINGS.
 - KEYSEATS ARE TO ANSI B17.1-1967, R1973.
 - DIMENSION "W" KEYSEAT WIDTH OVER .500 USES TOLERANCE OF +.003/- .000.
 - FOR GRID ONLY SEE DRAWING 448 0157 000.
 - BORES FURNISHED WITH CLEARANCE FIT AND SETSCREW OVER THE KEYWAY.

				DO NOT SCALE DRAWING PLOT SCALE 1 = 1		Pentair Water Pump Division North Aurora Operations		
A	08/25/08	INITIAL RELEASE	FRW	LF	COMPANY CONFIDENTIAL: Information contained herein is confidential, it is the property of Pentair Water. It is to be used solely for the purpose provided, and it is not to be disclosed to others without the prior written consent of Pentair Water.			
REV	DATE	REVISION	BY	CK'D				
NOTES: 1. FINISH = 125 RMS. 2. 2 PLACE DECIMALS ± .06. 3. 3 PLACE DECIMALS ± .010. 4. ANGULAR DIMENSIONS ± 1/2°. 5. CHAMF. ALL MACH'D. SURFACE .005--.010x45° AND REMOVE ALL BURRS. 6. ALL PARTS MUST BE FREE FROM SCALE. 7. NO TOLERANCE NEEDED ON REFERENCE DIMENSIONS. 8. ALL BOLT CIRCLE TOLERANCE PER ANSI B16.5. 9. CONCENTRICITY TO CENTERLINE .005.					STANDARD TOLERANCES UNLESS OTHERWISE SPECIFIED.		DRAWN BY FRW DATE 08/25/08 CHECKED BY FRW APPROVED BY LF	
					METAL GRID TYPE COUPLINGS CLARKE COUPLING SIZE C1080T			
					REV A		256 3200 000	
					SIZE B		THRU 256 3224 000	